

SEE SHEET 2 FOR WIRING SCHEMATIC

UNIVERSAL ANALYZERS INC. 1701 South Sutro Terrace Carson City, Nevada 89706 USA		F 11/06/07	Revised Per Sheet 2	RW	GE
REV	DATE	DESCRIPTION		DWN	APVD
REVISIONS					
DATE	SCALE	SIZE	SHEET		
09/10/1991	NTS	D	1 OF 2		
PART NO.		FOR		DRAWING NO.	
NOT ISSUED		N/A		P0005	
DRAWN BY		APVD BY			
E. Musselman		T. Barben			

8 | 7 | 6 | 5 | 4 | 3 | 2 | 1

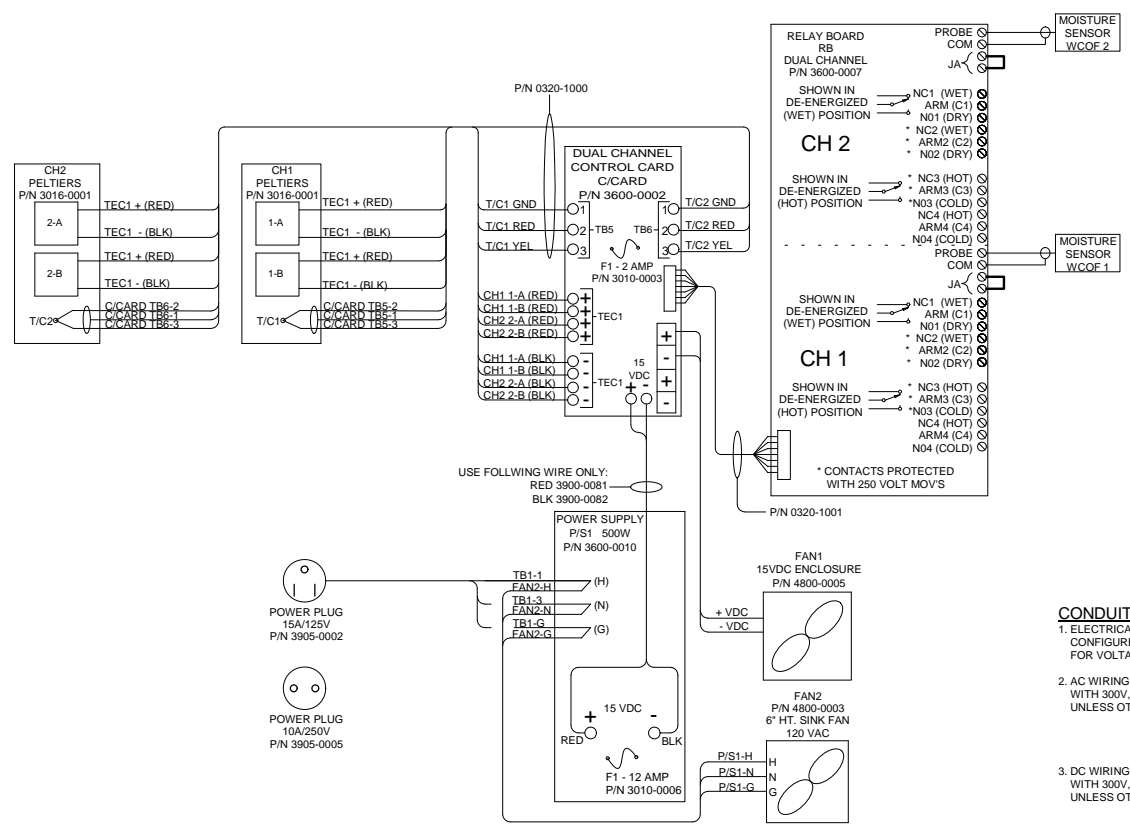

CONDUIT AND WIRING NOTES

- ELECTRICAL CLASSIFICATION: INSIDE - GENERAL PURPOSE SYSTEM IS CONFIGURED AT THE FACTORY FOR REQUIRED VOLTAGE. CONTACT FACTORY FOR VOLTAGE CHANGE REQUIREMENTS.
- AC WIRING SHALL BE INDIVIDUAL CONDUCTORS OF STRANDED TINNED COPPER WITH 300V, TYPE TFE INSULATION. MINIMUM WIRE SIZE SHALL BE 18 AWG UNLESS OTHERWISE SPECIFIED. COLOR CODE SHALL BE AS FOLLOWS:
HOT - BLACK
COMMON - WHITE
GROUND - GREEN
- DC WIRING SHALL BE INDIVIDUAL CONDUCTORS OF STRANDED TINNED COPPER WITH 300V, TYPE TFE INSULATION. MINIMUM WIRE SIZE SHALL BE 22 AWG UNLESS OTHERWISE SPECIFIED. COLOR CODE SHALL BE AS FOLLOWS:
+V - RED
0V - BLACK

RELAY BOARD NOTES

- USER CONNECTIONS TO MOISTURE SENSOR RELAY ENERGIZED WHEN SENSOR IS DRY (DRY LED ON). RATING: 1/10HP 120VAC 5A 240VAC/32VDC RESISTIVE.
- USER CONNECTIONS TO 'AT TEMPERATURE' RELAY ENERGIZED WHEN BELOW SET TEMPERATURE (COOL LED ON). RATING: 1/10HP 120VAC 5A 240VAC/32VDC RESISTIVE.

----- FIELD TO WIRE -----

UNIVERSAL ANALYZERS INC. 1701 South SuroTerrace Carson City, Nevada 89706 USA		F 11/06/07	Add Ferrite Beads For RF Suppression	RW	GE
MODEL 1080 SAMPLE COOLER WIRING SCHEMATIC		REVISIONS			
DATE	SCALE	NTS	SIZE	D	SHEET
09/10/1991					2 OF 2
DRAWN BY	E. Musselman	DRAWING NO.		P0005	
APVD BY	T. Barben	PART NO.		FOR N/A	
NOT ISSUED					

8 | 7 | 6 | 5 | 4 | 3 | 2 | 1