

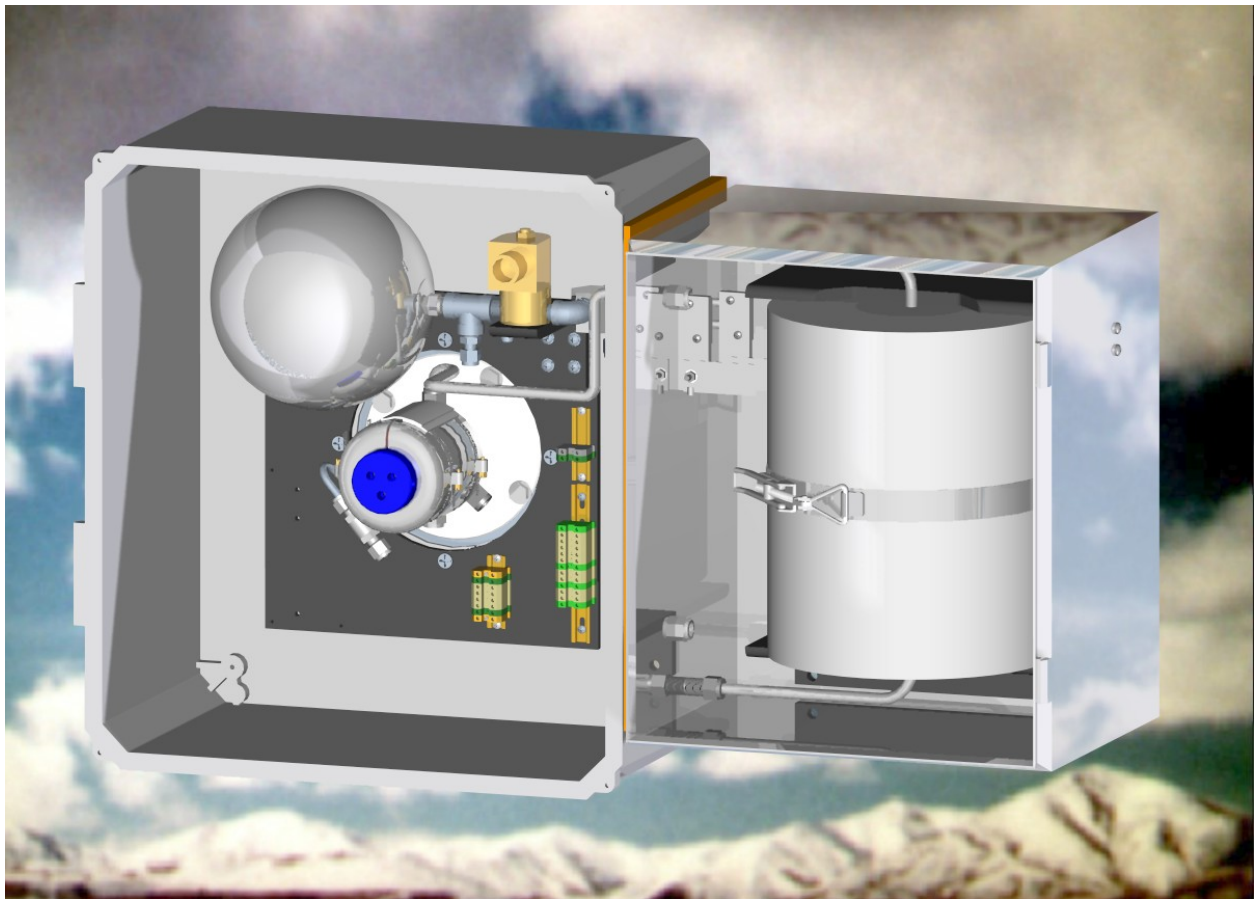

5200 Convair Drive
Carson City, NV 89706
775.883.2500 Fax 775.883.6388
www.universalanalyzers.com

270SF STACK FILTER WITH AMMONIA CONVERTER



See us on the WEB at <http://www.universalanalyzers.com>
e-mail address: sales@universalanalyzers.com
MAN-NH3 Rev G



5200 Convair Drive
Carson City, NV 89706
775.883.2500 Fax 775.883.6388
www.universalanalyzers.com

LIMITED WARRANTY

ALL PRODUCTS MANUFACTURED BY UNIVERSAL ANALYZERS INC. ARE WARRANTED TO BE FREE OF MANUFACTURING DEFECTS FOR A PERIOD OF ONE YEAR FROM THE DATE OF RECEIPT AT THE CUSTOMER'S RECEIVING AREA AND FOR AN ADDITIONAL PERIOD OF UP TO 90 DAYS IF THE PRODUCT IS PLACED IN SERVICE AFTER BEING IN STORAGE. THIS WARRANTY COVERS MATERIALS AND LABOR TO RESTORE ANY PRODUCTS TO ORIGINAL FACTORY SPECIFICATIONS IF A DEFECT IS FOUND WITHIN THE WARRANTY PERIOD.

THE DEFECTIVE PRODUCT SHOULD BE SENT, FREIGHT PREPAID, TO THE FACTORY IN CARSON CITY, NEVADA. REPAIRS WILL BE PERFORMED AT THE FACTORY AND RETURNED, PREPAID, BY THE SAME SHIPPING METHOD USED TO SEND THE PRODUCT TO THE FACTORY.

THIS WARRANTY DOES NOT APPLY WHERE THE EQUIPMENT HAS SUSTAINED DAMAGE DUE TO NEGLIGENCE, MODIFICATION, CORROSION, OR OTHER REASON BEYOND THE SCOPE OF THE NORMAL DEFINITION OF "MANUFACTURING DEFECT".

FURTHER, THIS WARRANTY IS LIMITED TO REPLACING THE DEFECTIVE COMPONENTS AND RETURNING THE EQUIPMENT MANUFACTURED BY UNIVERSAL ANALYZERS INC. TO THE CUSTOMER IN WORKING CONDITION. ANY OTHER CLAIMS ARE OUTSIDE THE SCOPE OF THIS WARRANTY. NO WARRANTIES ARE MADE AS TO THE SUITABILITY OF THE USE OF THE EQUIPMENT IN ANY PARTICULAR APPLICATION OR LOCATION. THE SUITABILITY OF THE USE OF THE EQUIPMENT IS THE RESPONSIBILITY OF THE CUSTOMER AND THE INSTALLING CONTRACTOR.

270SF SAMPLE PROBE WITH AMMONIA CONVERTER



OPERATING SPECIFICATIONS

SAMPLE FLOW RATE:	0 TO 10 LPM
CALIBRATION GAS REQUIREMENT:	SAMPLE FLOW RATE PLUS 10%
OPERATING PRESSURE DROP AT 10 LPM:	12" WATER COLUMN
MAXIMUM GAS TEMPERATURE AT INLET:	700° FAHRENHEIT
FILTER OVEN TEMPERATURE:	350° FAHRENHEIT
DIMENSIONS:	18" x 30" x 10" HWD
WEIGHT:	50 POUNDS (PLUS PROBE)
INPUT POWER REQUIREMENT:	1600 WATTS
INPUT VOLTAGE REQUIREMENT:	115 OR 230 VAC, 50/60 HZ
BLOWBACK TANK VOLUME:	0.7 SCF WHEN AT 100 PSIG
BLOWBACK DURATION:	TWO SECONDS SUGGESTED
BLOWBACK TIMER PERIOD:	CONTROLLED EXTERNALLY
BLOWBACK SOLENOID VALVE VOLTAGE:	AS SPECIFIED
MAXIMUM NH ₃ CONCENTRATION	20 PPM BY VOLUME

MATERIAL SPECIFICATIONS

ENCLOSURE:	SAMPLE PROBE: FIBERGLASS OR 304SS (NEMA 4X) AMMONIA CONVERTER: PAINTED STEEL (NEMA 4X)
SAMPLE LINE CONNECTION:	3 INCH HEAT SHRINK BOOT
FILTER HEATER TYPE:	ROD HEATERS IN ALUMINUM TUBE, CONTROLLED WITH INTEGRAL THERMAL SWITCH
OVEN INSULATION MATERIAL:	JACKETED FIBERGLASS
FILTER CHAMBER MATERIAL:	316 STAINLESS STEEL
FILTER ELEMENT TYPES:	2 MICRON CERAMIC OR 316SS FILTER ELEMENTS; CERAMIC ELEMENT WITH 0.1 MICRON COATING INSIDE
AMMONIA CONVERTER HEATER TYPE:	CERAMIC FIBER HEATER (CONTROLLED REMOVEDLY, SENSED WITH TYPE K THERMOCOUPLE)

APPLICATION

The Universal Analyzers Ammonia Converter includes a Model 270 Heated Stack Filter. The assembly is designed to sample the gas in stacks where ammonia is added and must be analyzed. There is a sample tap located after the filter and before the converter. There is a second sample connection after the converter. NO is analyzed on samples from both locations. The difference in NO concentration is a measure of the amount of ammonia that has been converted.

The assembly will mount onto a 2", 3" or 4" flange connection to the stack as specified. The stinger or probe screws into the mounting flange. Stack temperatures and the corrosive gasses which may be present will determine the material and design of the probe to be used. A variety of materials are available for stacks having temperatures as high as 3000° F. (1650° C.).

Sample flow rates of up to 10 liters per minute can be extracted, filtered and processed through the Model 270 Heated Filter and Ammonia Converter with a minimal amount of pressure drop.

GENERAL DESCRIPTION, HEATED FILTER SECTION

The Heated Stack Filter Section of the NH₃ Conversion Assembly consists of the 270 heated filter mounted on the left side of the converter contains a blowback solenoid valve to be activated by external means. An acid blocking component is provided to protect the valve from acid in the sample. The solenoid valve can be provided with any of the available solenoid coils to allow the external control system to provide the opening coil power which is most convenient.

The NEMA 4X enclosure is fastened directly to the mounting flange which is sized to match the mating sample flange on the stack. There is a heatshrink boot on the bottom of the enclosure to accept a heated sample line. When the heated sample line is properly supported, the flange mounting of the enclosure is sufficient to support the entire assembly.

A 125 Watt Heater Assembly is mounted on the outside of the filter cavity. The heater holds the temperature of the filter at 340° F. A bi-metallic thermal switch fused to the heater keeps the temperature from exceeding 340° F by opening the circuit at that temperature. An optional independent thermocouple/RTD can be provided as a means to measure and transmit or record the temperature of the filter. A second thermal switch, set at 225° F. (105° C.) is provided to be used as an alarm contact if the temperature drops below the switch temperature.

Several types of filter elements can be supplied with the Model 270. The 2 micron ceramic filter is supplied as an economical general purpose filter. A similar ceramic filter with an internal 0.1 micron coating is available for finer filtration or to provide a surface to enhance the blow back capability where the fines have a tendency to fill the pores of the 2 micron element. A 2 micron, 316 Stainless Filter can be inserted for those applications where the ceramic filter is determined to be unsuitable. Additional filtration materials and pore sizes are available on request.

The blowback accumulator is a 7" diameter stainless steel sphere. It is designed to be pressurized to a maximum pressure of 125psig compressed air. At that pressure there is a ½ cubic foot of air stored to flush the particulate matter out of the filter and through the probe into the stack.

Compressed air is used to clean the filter element. Compressed air supplied to the blow back assembly needs to be clean and dry. Instrument quality air is preferred. The pressure should be as high as possible, up to 125psig. High pressure air fills the accumulator and provides a substantial blast when the solenoid valve opens. This loosens the particles on the filter surface and forces them back through the sample probe into the stack. The period of time between blow back cycles should be commanded to occur before the pressure drop across the filter begins to increase. This should be as often as every fifteen minutes but no less frequently than once per day. The time period between blow back cycles can be based on a calculation to estimate the amount of sample required to deposit from three to five grams of solids in the filter element.

Instrument air usage is minimal and smoothed by the fact that the air accumulator is charged over a period of time through a ¼" instrument air line. The recharge time could be extended with a restriction in the air line if it were desired to reduce the pressure pulses on the instrument air supply and to consume instrument air more slowly.

The calibration gas is injected into the chamber ahead of the filter. This is close to the sample source as is required by many EPA officers. A back pressure check valve (set at 3 to 5 psig) is provided in the cal gas injection path to insure that calibration gas does not leak into the sample while the sample is being drawn through the filter.

GENERAL DESCRIPTION, AMMONIA CONVERSION SECTION

The ammonia conversion occurs at elevated temperatures on the surface of 316SS disks in a thermal reactor. Drawing A0276 describes the reactor. The temperature of the oven containing the reactor can be adjusted with a temperature controller (supplied or by others) using the internal Type "K" Thermocouple welded to the reactor. Suggested temperatures range from 1200 degrees F. to about 1400 degrees F. The oven containing the reactor can safely be controlled at temperatures up to 1500 degrees F, however the stainless steel surfaces oxidize along with the ammonia at the high end of the range.

As the sample passes through the reactor, all NO_x and NH₃ are thermally oxidized into Nitric Oxide (NO). Reaction of NH₃ proceeds according to this exothermic reaction:

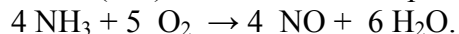

For maximum conversion efficiency & long reaction life (several years), please observe the following requirements:

- Ratio of O₂ to NH₃ should be greater than 1.25.
- Flow through reactor should be limited to 1 – 1.5 LPM.
- Do not expose reactor to ammonia concentrations > 20 PPM.
- Minimize (NH₃ PPM * hours * flow rate) for longest reactor life.

INSTALLATION INSTRUCTIONS

Each stack or duct where the Ammonia Conversion Assembly requires a flange connection to match the flange on the Assembly. The flange face should be vertical or canted slightly off of vertical so that the probe mounted to the assembly will be level or pointing slightly downward. This will allow any entrained liquid in the sample to drain back into the stack. The length of the probe should be selected to extend into the center one third of the stack; or if the stack diameter is greater than 18', at least 6' into that stack.

A heated sample line should be supported close to the Assembly. The heated sample line should be fed through the heat shrink boot on the bottom of the NEMA 4X enclosure. Connect the two sample tubes to the appropriate connections before and after the converter. The unheated portions of the sample lines should be kept short and insulated to avoid condensation. Connect the cal gas line through the back pressure check valve to the 1/4" tubing fitting. If the compressed air line is part of the heated sample line, it can be connected to the fitting directly next to the heated accumulator. If an external air line is to be used for blow back, bring the air into the enclosure through a bulkhead fitting to be installed in the wall of the enclosure and connect the air to the same fitting next to the heated accumulator.

Provide power to the terminal blocks within the electrical box on the 270SF. See the drawings in this manual for the wiring schematic that supports the model being wired. Insure the power supplied to the heated stack filter matches the voltage requirement shown on the serial number tag. The voltage requirement can be changed by changing the jumpers on the terminal strip. The two jumpers labeled "115" are in place for 115 VAC operation. The jumper labeled "230" would be in place for 230VAC operation (with the 115 VAC jumpers removed). They can be changed in the field, however, **the solenoid valve must be rated for the voltage provided to the 270SF**. An independent ground wire should be run to the grounding terminal on the terminal strip.

The terminals labeled "LOW TEMP" are connected to a dry circuit thermal switch mounted on the heater tube, next to the heater control switch. This may be connected to an external alarm to indicate a low temperature condition within the filter. The switch will "open" above 105° C.

If an independent measurement and display of the oven temperature is desired, an optional thermocouple or RTD can be slipped into a 1/8" diameter thermal well supplied within the heater tube.

Provide a thermocouple extension cable to bring the temperature signal from the internal Type "K" Thermocouple wire in the reactor oven to the external temperature controller. The output of the temperature controller should be connected to a solid state relay which controls power to the ceramic filter heaters surrounding the NH₃ converter.

Provide switched power to TB2 within the enclosure. About 1250 watts of power, is required. It is possible to convert the Ammonia Conversion Assembly to 230 VAC in the field. Consult factory for details. Insure the power supplied to the assembly matches the voltage requirement shown on the serial number tag. An independent ground wire should be run to the grounding terminal on the terminal strip.

Connect the blow back control wiring to TB1.

If an independent measurement and display of the filter oven temperature is desired, a thermocouple can be slipped into a 1/8" diameter thermal well supplied within the heater assembly.

The final installation step is to insure that the sample line is insulated within the enclosure. Close the cover of the enclosure and replace the safety screws on the latches. The goal is to keep the temperature of the gas samples at a temperature above the dew point of the gas all the way from the stack to the sample cooler/dehydrator.

START-UP PROCEDURE

Apply power to the unit. Allow the filter and oxidization reactor to come to temperature. This warm-up period is extremely important to avoid the condensation within the Model 270 filter which would cement the particulates to the filter surface.

Start the gas sample pump(s) and determine that the proper amount of sample is being supplied to the instrumentation.

Run a calibration cycle to insure that the calibration lines are properly installed and sealed. A flow meter should be installed in the calibration gas supply line to insure that there is at least 10 percent more calibration gas being supplied to the assembly than is being withdrawn as samples. That will insure that the filter and probe are being properly flooded with calibration gas. The excess calibration gas will be discharged through the probe.

Open the instrument air valve to charge the blow-back accumulator. Exercise the blow back solenoid valve to insure it is properly wired. After a blow-back cycle, the presence of a slight pulse on the sample tubing in the analyzer house and the momentary dilution of the samples with instrument air is normal and signifies that a blow back cycle has occurred.

The optimum time between blow back cycles is to be determined by experience. Once a day is sufficient in relatively clean applications. The requirement could be as frequent as every fifteen minutes where the dust and soot levels are severe. It is better to blow back too often than not enough. A vacuum gage in the sample line can be helpful to indicate if the particulate loading of the filter has started to restrict the flow of sample. That condition should not be allowed to occur. The blow back should be initiated before observing a change in pressure drop.

AMMONIA OXIDATION TEMPERATURES

It is suggested that the temperature of the reactor oven be first controlled to 1250° F. to determine if satisfactory ammonia conversion efficiencies can be obtained at that temperature. Some have reported as high as 95% conversion efficiency at that temperature. Others have run the oven at 1500 degrees F. for satisfactory conversion efficiencies.

It has been reported that raising the temperature of the reactor oven above 1500° F. does not improve the conversion efficiency. One report showed that the conversion efficiency actually dropped at 1800° F.

CHANGING THE FILTER

Caution: this procedure can cause severe burns. Use proper protection.

Changing the filter in the Model 270 Heated Filter Assembly is extremely easy. Open the door to the Heated Filter. Using gloves to protect the hand, grasp the cap on the end of the filter body opposite the probe and turn it counter clockwise. **The cover may be hot to the touch and may cause burns to the hand if not protected.** Removing the cover exposes the filter. Reach into the heated oven with pliers to pull out the old filter.

Inspect the o-rings which are at each end of the filter to insure they are still elastic and will seal the filter. Replace them if they are charred or deformed.

Replace the filter with a new one, again handling it with pliers. Insure it is pushed in the center of the oven so that it is in contact with the o-ring at the inside end of the filter. Screw the cap back on the filter body. Close the door and replace the safety screws. The filter replacement procedure is complete.

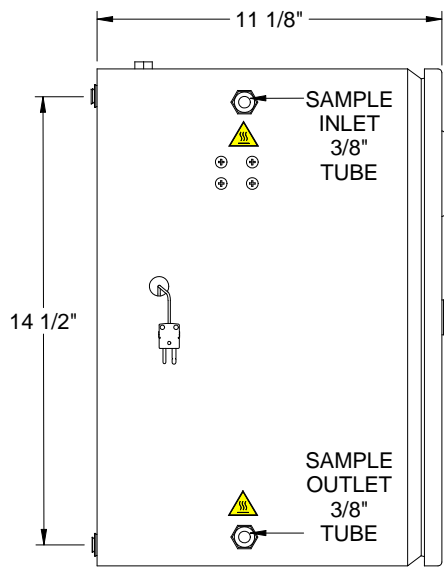

LEFT VIEW

NOTE: ROTATE OVEN TRAP CLAMP APPX. 30° TO PREVENT THE LATCH FROM COLLIDING WITH THE INSIDE OF THE FRONT DOOR.

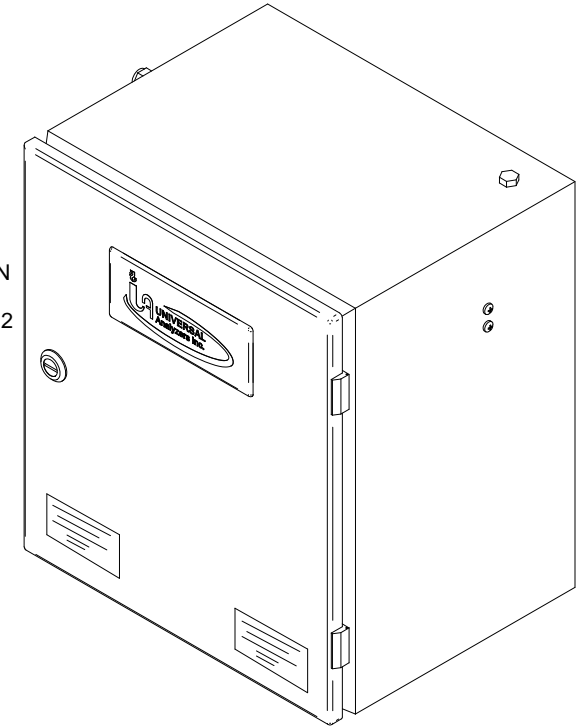
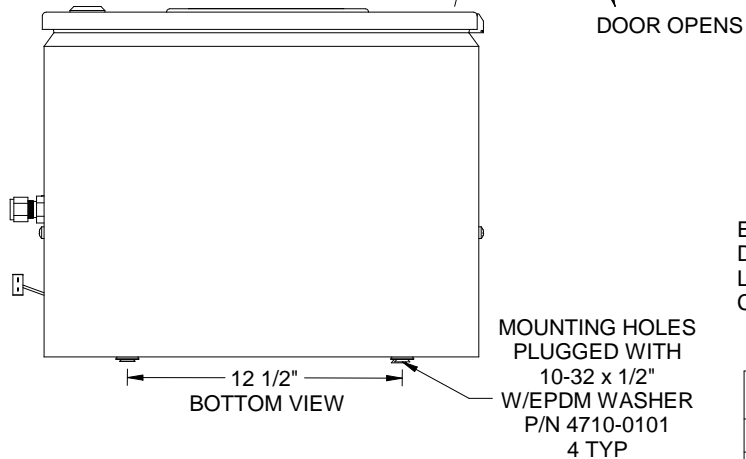
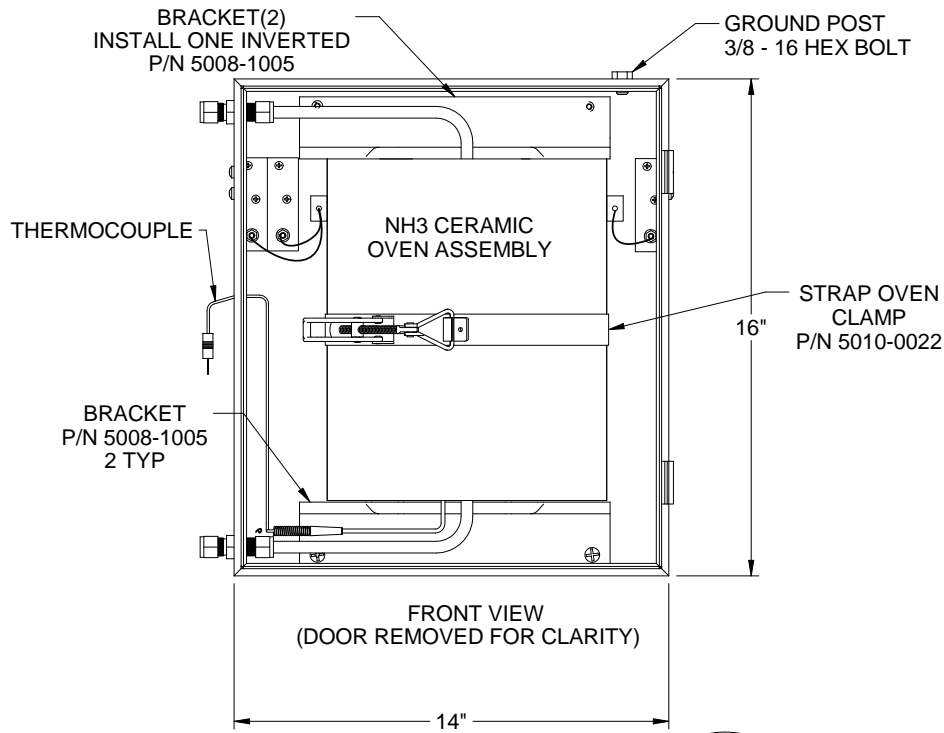

LABEL SET		
REQ'D	DESCRIPTION	U.A.I. P/N
1	NAME PLATE	5001-1005
1	MADE IN USA LABEL	5001-0028
1	WARNING NON-HAZARD	5001-0026
1	HAZARDOUS VOLTAGE, HEAT	5001-1050
1	ELECTRIC SHOCK SYMBOL	5001-0128
2	HOT SURFACE WARNING	5001-0058

ENCLOSURE ASSEMBLY AVAILABLE WITH DOOR HINGES AND SAMPLE TUBES FOR LEFT OR RIGHT OPENING. RIGHT OPENING CONFIGURATION ON PAGES 3 AND 4.

UNIVERSAL ANALYZERS INC. 5209 Conrail Drive Carson City, Nevada 89706 USA		A	10/01/08	Revised Per As Built	RW	DA
NH3 CONVERTOR ASSEMBLY LEFT TO RIGHT ARRANGEMENT		REV	DATE	DESCRIPTION	DWN/APVD	
PART NO. 5209-1019		DATE 01/30/2008		REVISIONS	SCALE 1:2	SIZE D
FOR INSTRUMENT		DRAWN BY E. Musselman		DRAWING NO. P1217		
		APVD BY		SHEET 1 OF 5		

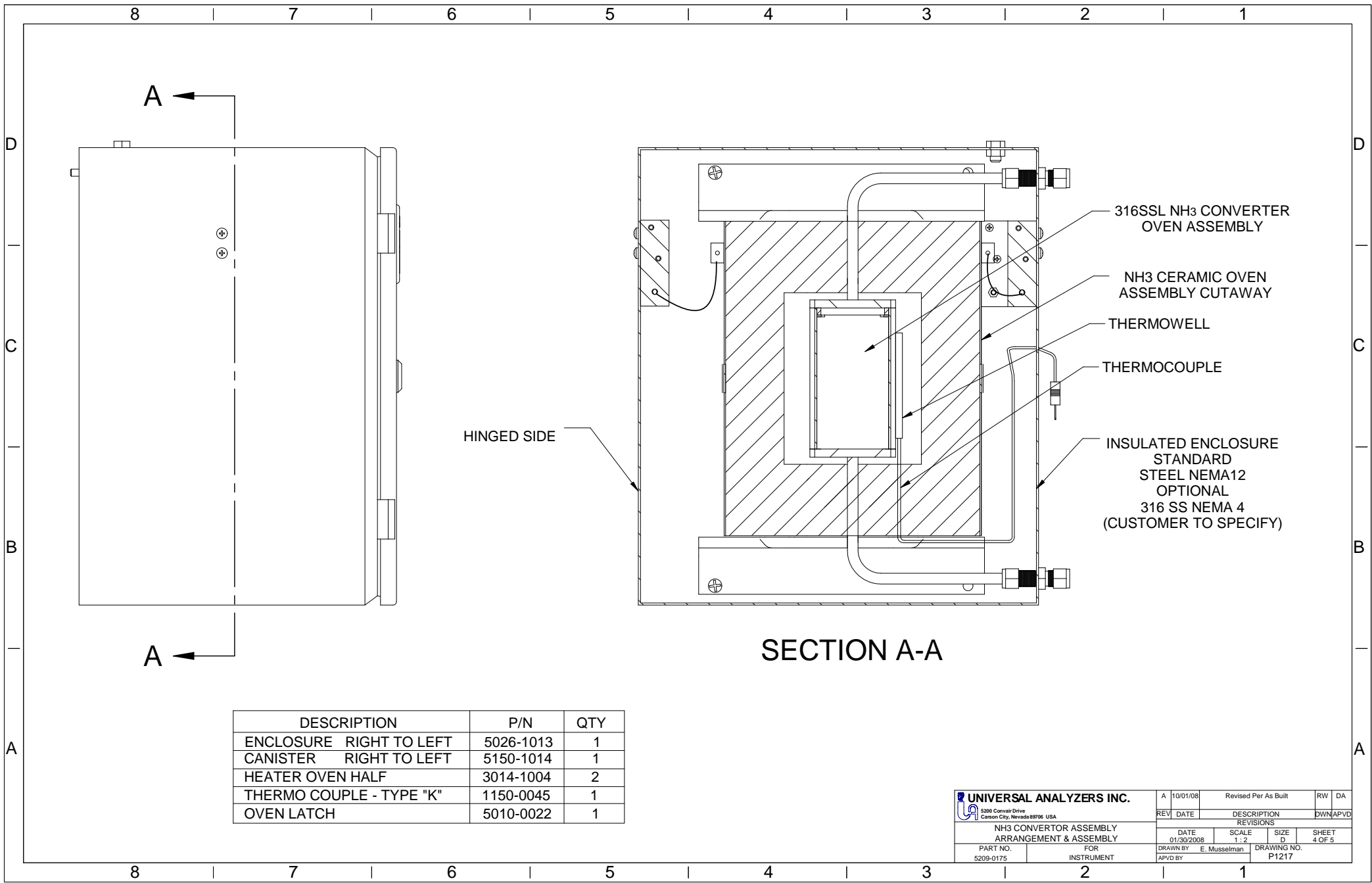

HINGED SIDE

- 316SS NH₃ CONVERTER OVEN ASSEMBLY
- NH₃ CERAMIC OVEN ASSEMBLY CUTAWAY
- THERMOWELL
- THERMOCOUPLE
- INSULATED ENCLOSURE
STANDARD
STEEL NEMA12
OPTIONAL
316 SS NEMA 4
(CUSTOMER TO SPECIFY)

SECTION A-A

DESCRIPTION	P/N	QTY
ENCLOSURE RIGHT TO LEFT	5026-1013	1
CANISTER RIGHT TO LEFT	5150-1014	1
HEATER OVEN HALF	3014-1004	2
THERMO COUPLE - TYPE "K"	1150-0045	1
OVEN LATCH	5010-0022	1

UNIVERSAL ANALYZERS INC.		A	10/01/08	Revised Per As Built	RW	DA
5209 Conrail Drive Carson City, Nevada 89706 USA		REV	DATE	DESCRIPTION	DWN/APVD	
REVISIONS						
NH ₃ CONVERTOR ASSEMBLY ARRANGEMENT & ASSEMBLY		DATE	SCALE	SIZE	SHEET	
PART NO. 5209-0175		FOR INSTRUMENT	01/30/2008	1:2	D	4 OF 5
DRAWN BY APVD BY		E. Musselman		DRAWING NO. P1217		

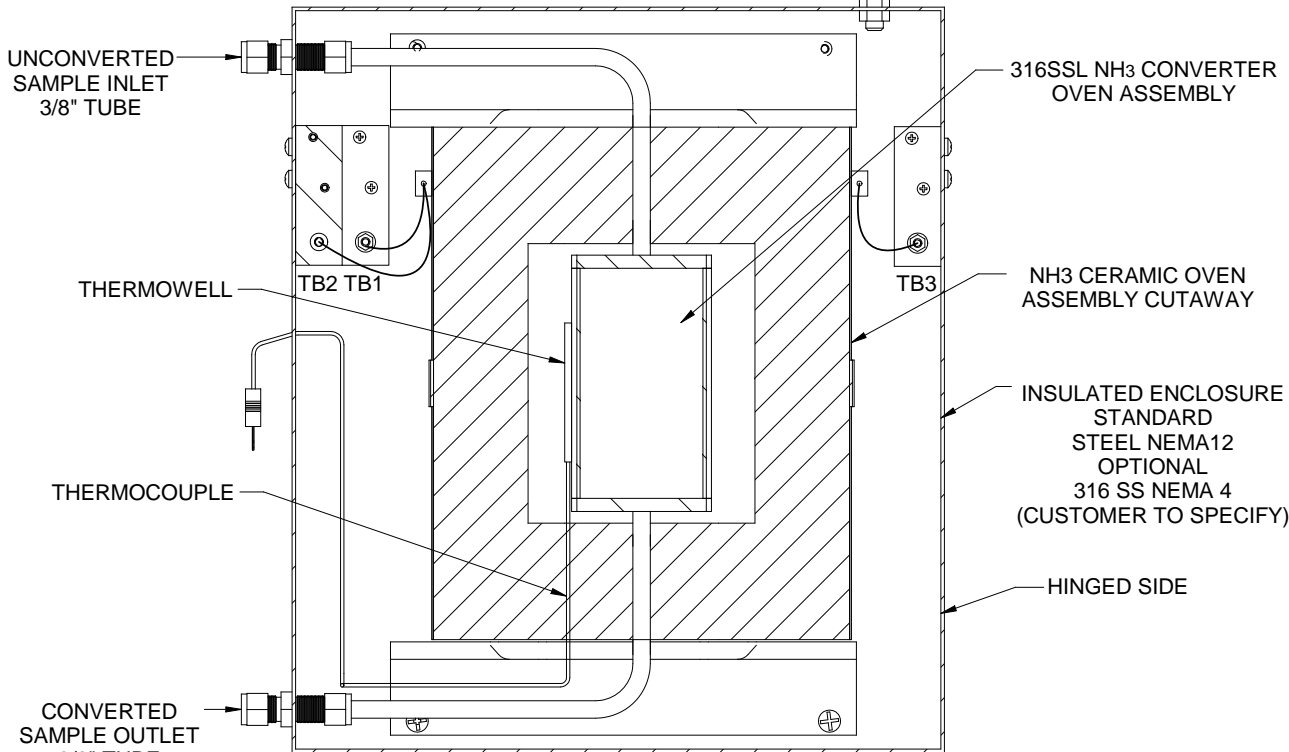
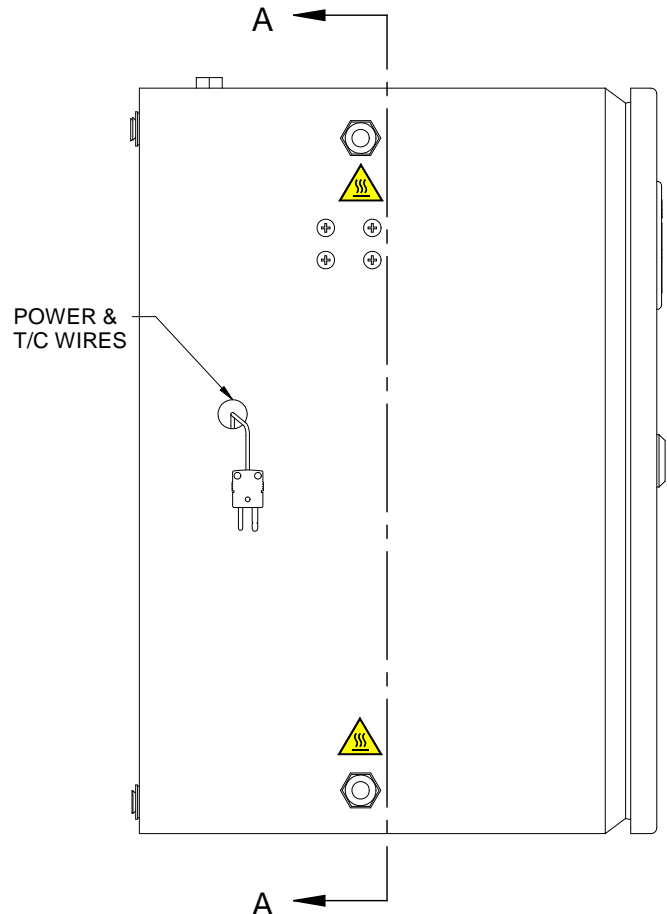

SECTION A-A

DESCRIPTION	P/N	QTY
ENCLOSURE LEFT TO RIGHT	5026-0208	1
CANISTER LEFT TO RIGHT	5150-0594	1
HEATER OVEN HALF	3014-1004	2
THERMO COUPLE - TYPE "K"	1150-0045	1
OVEN LATCH	5010-0022	1

UNIVERSAL ANALYZERS INC. 5209 Conrail Drive Carson City, Nevada 89706 USA		A	10/01/08	Revised Per As Built	RW	DA	
NH3 CONVERTOR ARRANGEMENT & ASSEMBLY FOR INSTRUMENT		REVISIONS				DWN	APVD
		DATE	SCALE	SIZE	SHEET		
PART NO. 5209-1019	FOR INSTRUMENT	01/30/2008	1:2	D	2	OF 5	
DRAWN BY E. Musselman		APVD BY		DRAWING NO. P1217			

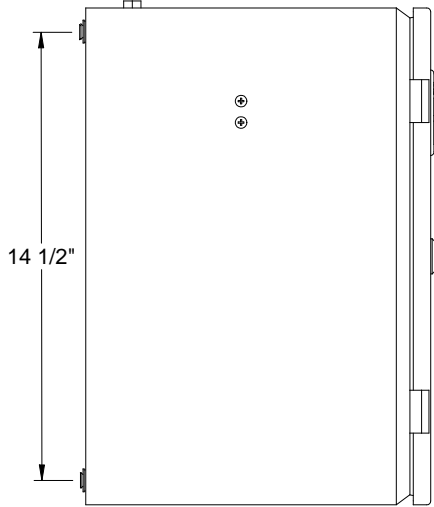

LEFT VIEW

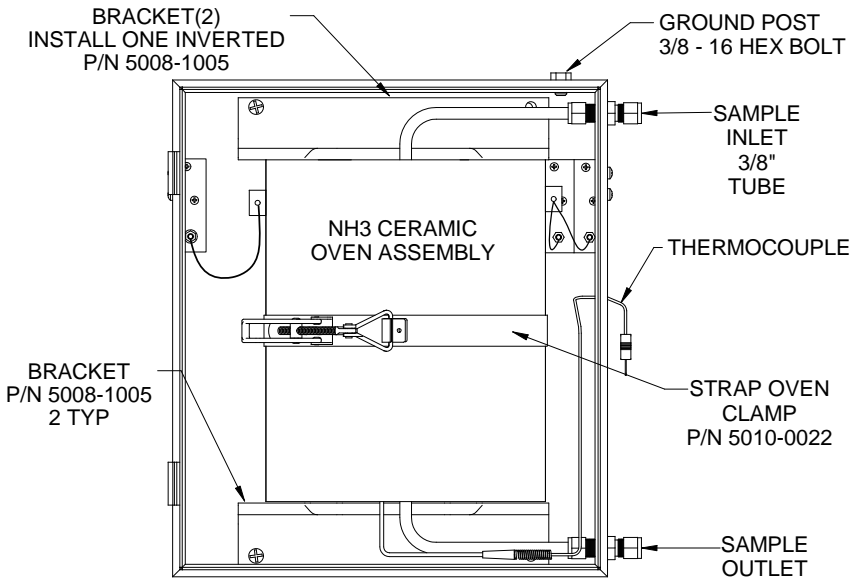

FRONT VIEW
(DOOR REMOVED FOR CLARITY)

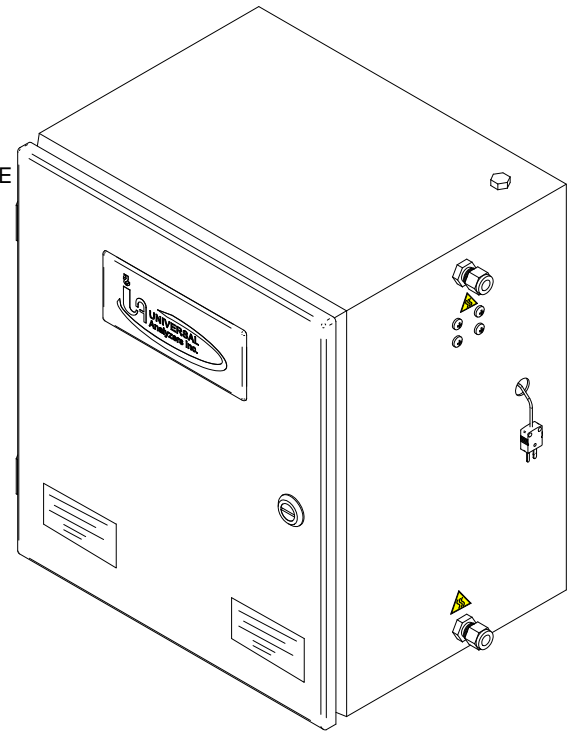

ISOMETRIC VIEW

NOTE: ROTATE OVEN TRAP CLAMP APPX. 30° TO PREVENT THE LATCH FROM COLLIDING WITH THE INSIDE OF THE FRONT DOOR.

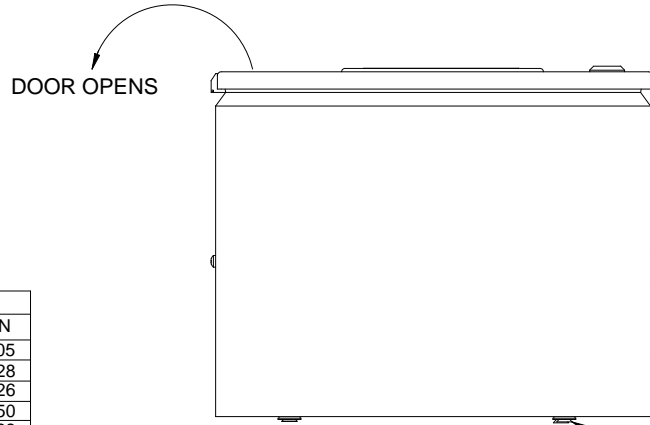

BOTTOM VIEW

MOUNTING HOLES PLUGGED WITH 10-32 x 1/2" W/EPDM WASHER P/N 4710-0101 4 TYP

ENCLOSURE ASSEMBLY AVAILABLE WITH DOOR HINGES AND SAMPLE TUBES FOR LEFT OR RIGHT OPENING.

LABEL SET		
REQ'D	DESCRIPTION	U.A.I. P/N
1	NAME PLATE	5001-1005
1	MADE IN USA LABEL	5001-0028
1	WARNING NON-HAZARD	5001-0026
1	HAZARDOUS VOLTAGE, HEAT	5001-1050
1	ELECTRIC SHOCK SYMBOL	5001-0128
2	HOT SURFACE WARNING	5001-0058

UNIVERSAL ANALYZERS INC. 5209 Conrail Drive Carson City, Nevada 89706 USA		A	10/01/08	Revised Per As Built	RW	DA
NH3 CONVERTOR ASSEMBLY RIGHT TO LEFT ARRANGEMENT		REV	DATE	DESCRIPTION	REVISIONS	
PART NO. 5209-0175	FOR INSTRUMENT		01/30/2008		SCALE 1:2	SIZE D
DRAWN BY E. Musselman		APVD BY		DRAWING NO. P1217		
				SHEET 3 OF 5		

8 | 7 | 6 | 5 | 4 | 3 | 2 | 1

OPTIONAL 115 VAC CONFIGURATION

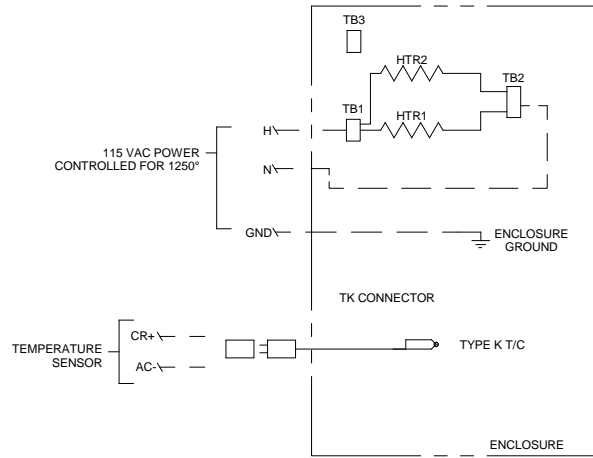

STANDARD 230 VAC CONFIGURATION

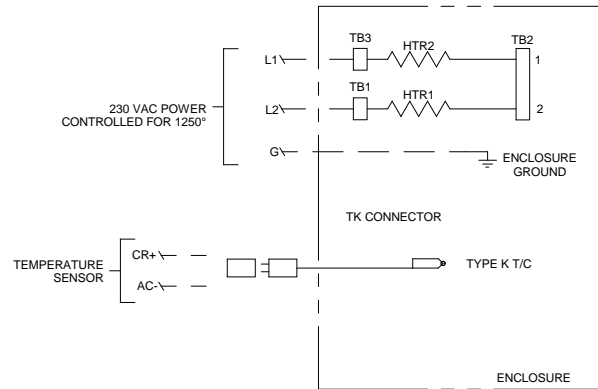

NOTES:
HTR 1 IS TOWARDS FRONT OF THE ENCLOSURE
HTR 2 IS TOWARDS REAR OF THE ENCLOSURE

8 | 7 | 6 | 5 | 4 | 3 | 2 | 1

UNIVERSAL ANALYZERS INC.		A	10/01/08	Revised Per As Built	RW	DA
5200 Conrail Drive Carson City, Nevada 89706 USA		REV	DATE	DESCRIPTION	DWN/APVD	
REVISIONS						
NH3 CONVERTOR ASSEMBLY ARRANGEMENT		DATE	SCALE	SIZE	SHEET	
PART NO. 5209-1019&0175		01/30/2008	1:2	D	5 OF 5	
FOR INSTRUMENT		DRAWN BY E. Musselman	DRAWING NO. P1217		APVD BY	

D
C
B
A

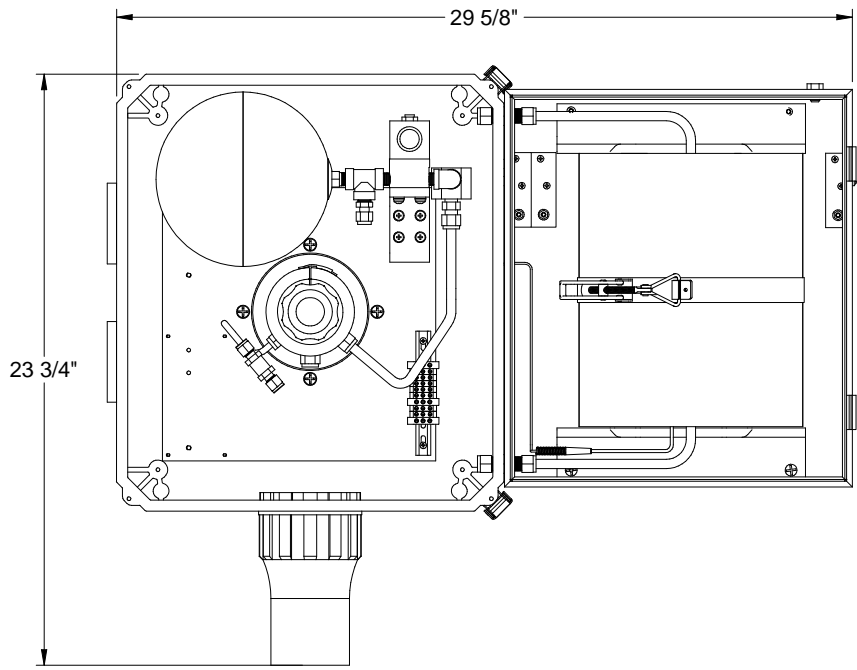

FRONT VIEW

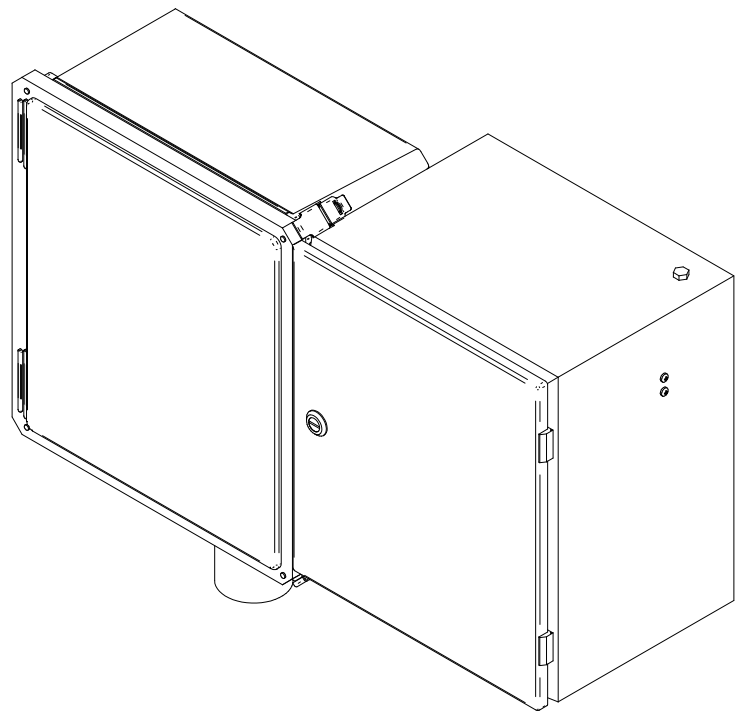

ISOMETRIC VIEW

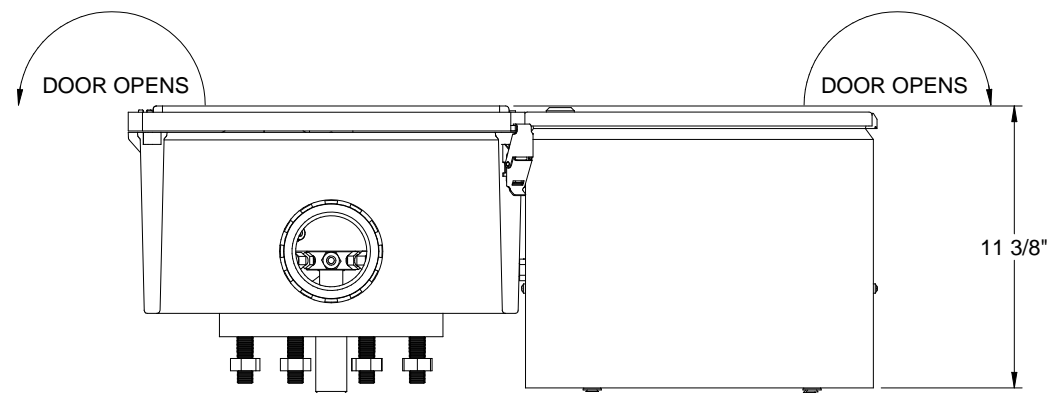

BOTTOM VIEW

UNIVERSAL ANALYZERS INC. 5200 Conrail Drive Carson City, Nevada 89706 USA		A	10/13/08	A Rev To Match Part Numbers	RW	DA
REV		DATE		DESCRIPTION	DWN/APVD	
REVISIONS						
DATE		SCALE		SIZE	SHEET	
10/13/2008		NTS		D	1 OF 1	
DRAWN BY		FOR		DRAWING NO.		
APVD BY				P1376		

**ACCESSORIES AND SPARE PARTS
FOR 270SF SERIES HEATED STACK FILTER in NEMA 4X
ENCLOSURE
& AMMONIA OXIDIZER CONVERTER**



5200 CONVAIR DR
CARSON CITY, NV 89706
PHONE: (775) 883-2500
FAX: (775) 883-6388

Level A, Consumable Supplies:

	<u>1 Yr.</u>	<u>2 Yr.</u>
4980-0007* 2 Micron Filter, Ceramic	4ea	8ea
4904-0015 Filter o-ring seal, Viton, #2-208	2ea	4ea
4904-0016 Plug o-ring seal, Viton, #2-216	1ea	2ea
8010-0001 Heater Rod Paste		1ea

Level B, Basic Spare Parts:

3014-0046 Heater Rod, 3/8" Dia. x 1.5" Lg. 63Watt		2ea
3103-0014 Switch, Chamber Heater Temp. (NC Below 340° F)		1ea
3103-0012 Switch, Low Temp. (Blue - NO Below 225°F)		1ea
4955-0010 Solenoid Blow-back Valve, 24VDC		1ea
4956-0001 Accumulator Sphere, Blow-back, Unheated		
5110-0015 Acid Blocker Assembly		
5150-0014 Cal Gas Check Valve, Adjustable Pressure		1ea
5209-0118 Knob Assembly for 270SF Series (High Temp)		
1150-0045 Thermocouple Type-K for Ammonia Oxidizer		1ea
5150-0594 Reactor Canister		1ea
3014-1004 Ceramic Fiber Heater Half		

* Commissioning Spare Part